

Plastic-Encapsulate Transistors

TRANSISTOR (NPN)

FEATURES

- PNP Complement to BC869U
- High current
- Low voltage

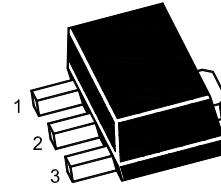

1.Base 2.Collector 3.Emitter
SOT-89 Plastic Package

MAXIMUM RATINGS ($T_a=25^\circ\text{C}$ unless otherwise noted)

Symbol	Parameter	Value	Unit
V_{CBO}	Collector-Base Voltage	32	V
V_{CEO}	Collector-Emitter Voltage	20	V
V_{EBO}	Emitter-Base Voltage	5	V
I_C	Collector Current -Continuous	1	A
P_C	Collector Power Dissipation	500	mW
T_J	Junction Temperature	150	$^\circ\text{C}$
T_{stg}	Storage Temperature	-55~150	$^\circ\text{C}$

ELECTRICAL CHARACTERISTICS ($T_a=25^\circ\text{C}$ unless otherwise specified)

Parameter	Symbol	Test conditions	Min	Typ	Max	Unit
Collector-base breakdown voltage	$V_{(BR)CBO}$	$I_C=100\mu\text{A}, I_E=0$	32			V
Collector-emitter breakdown voltage	$V_{(BR)CEO}$	$I_C=1\text{mA}, I_B=0$	20			V
Emitter-base breakdown voltage	$V_{(BR)EBO}$	$I_E=100\mu\text{A}, I_C=0$	5			V
Collector cut-off current	I_{CBO}	$V_{CB}=25\text{V}, I_E=0$			0.1	μA
Emitter cut-off current	I_{EBO}	$V_{EB}=5\text{V}, I_C=0$			0.1	μA
DC current gain	$h_{FE(1)}$	$V_{CE}=1\text{V}, I_C=500\text{mA}$	85		375	
	$h_{FE(2)}$	$V_{CE}=1\text{V}, I_C=1\text{A}$	60			
	$h_{FE(3)}$	$V_{CE}=10\text{V}, I_C=5\text{mA}$	50			
Collector-emitter saturation voltage	$V_{CE(sat)}$	$I_C=1\text{A}, I_B=100\text{mA}$			0.5	V
Base-emitter voltage	V_{BE1}	$V_{CE}=10\text{V}, I_C=5\text{mA}$		0.62		V
	V_{BE2}	$V_{CE}=1\text{V}, I_C=1\text{A}$			1	V
Transition frequency	f_T	$V_{CE}=5\text{V}, I_C=10\text{mA}, f=100\text{MHz}$	40			MHz

CLASSIFICATION OF $h_{FE(1)}$

Rank	BC868-10U	BC868-16U	BC868-25U
Range	85-160	100-250	160-375
Marking	CBC	CCC	CDC



SOT-89 PACKAGE OUTLINE

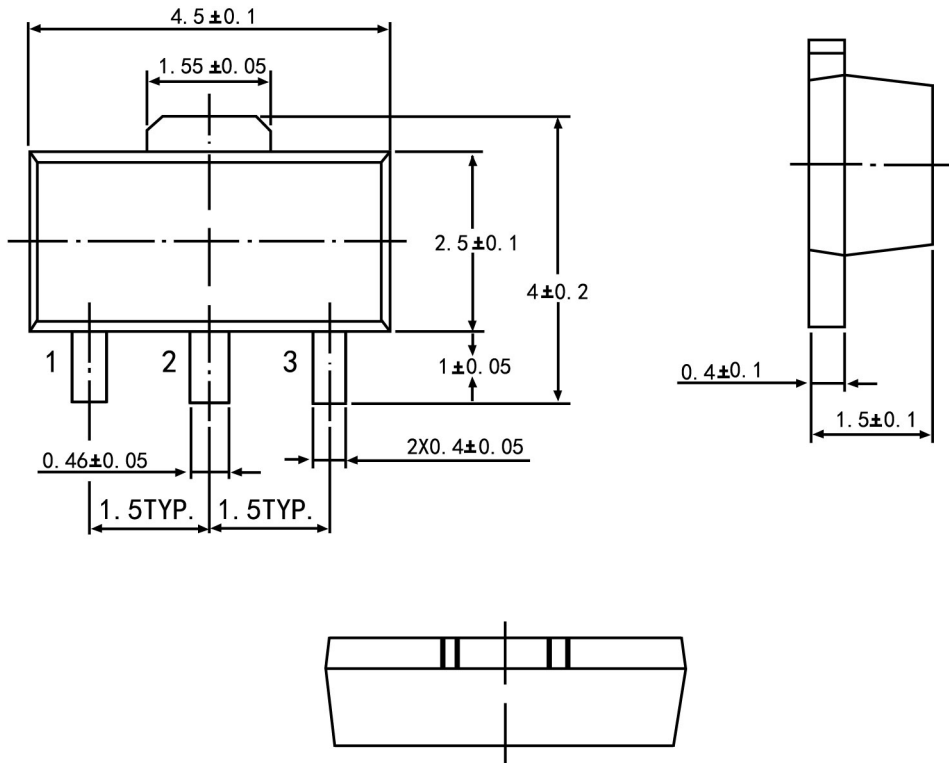

Symbol	Dimension in Millimeters	
	Min	Max
A	1.40	1.60
B	0.44	0.62
B1	0.35	0.54
C	0.35	0.44
D	4.40	4.60
D1	1.62	1.83
E	2.29	2.60
e	1.50 Typ	
H	3.94	4.25
H1	2.63	2.93
L	0.89	1.20
All Dimensions In mm		